

Model

5RB

PowerPrime

Pumps



5RB Overview:

The 8 inch (203.2mm) 5RB Clean Prime™ is an extremely robust pump unit, capable of flow rates to 3000 GPM, total dynamic heads to 370 feet (112.8M), and solids handling capabilities up to 1 inch (25.4mm) in diameter. The 5RB also features the Power Prime™ Pumps high pressure Tungsten vs. Silicon Carbide mechanical seal that allows for indefinite dry running, ideal for intermittent flow applications as well as our proprietary Clean Prime™ self-priming system that mitigates any product blow by in the venture priming system while maintaining suction lift capabilities of up to 28 feet. All of these features come standard on a compact skid or trailer for convenient use.

Standard Features:

- Hot Dip Galvanized Trailer
- Radiator enclosure
- John Deere Emissions Certified Engines
- Locking Battery Box

Optional DOT LED lights
Optional Floats

Pump Features:

- Solids-handling capabilities to 1" diameter maximum
- Continuous self-priming
- Runs dry unattended
- Suction lift up to 28 ft.
- Auto-start-capable control panel

Pump Performance Curve:

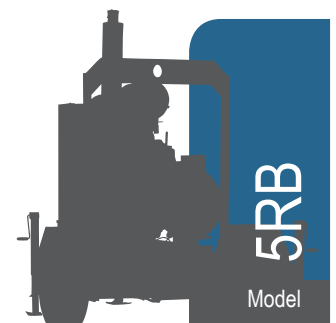
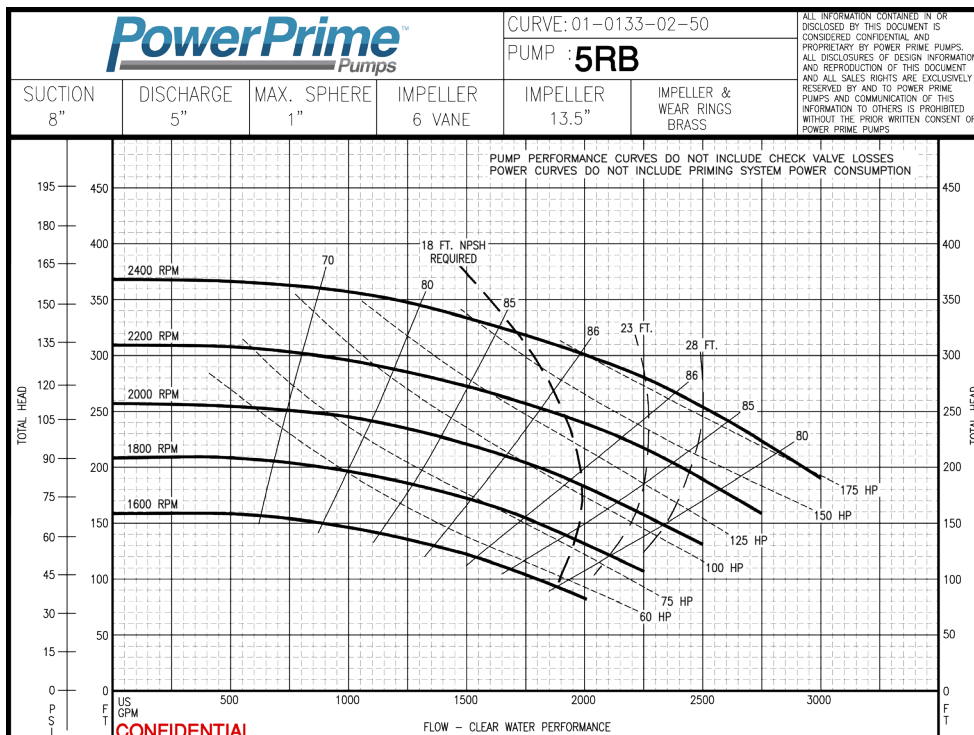

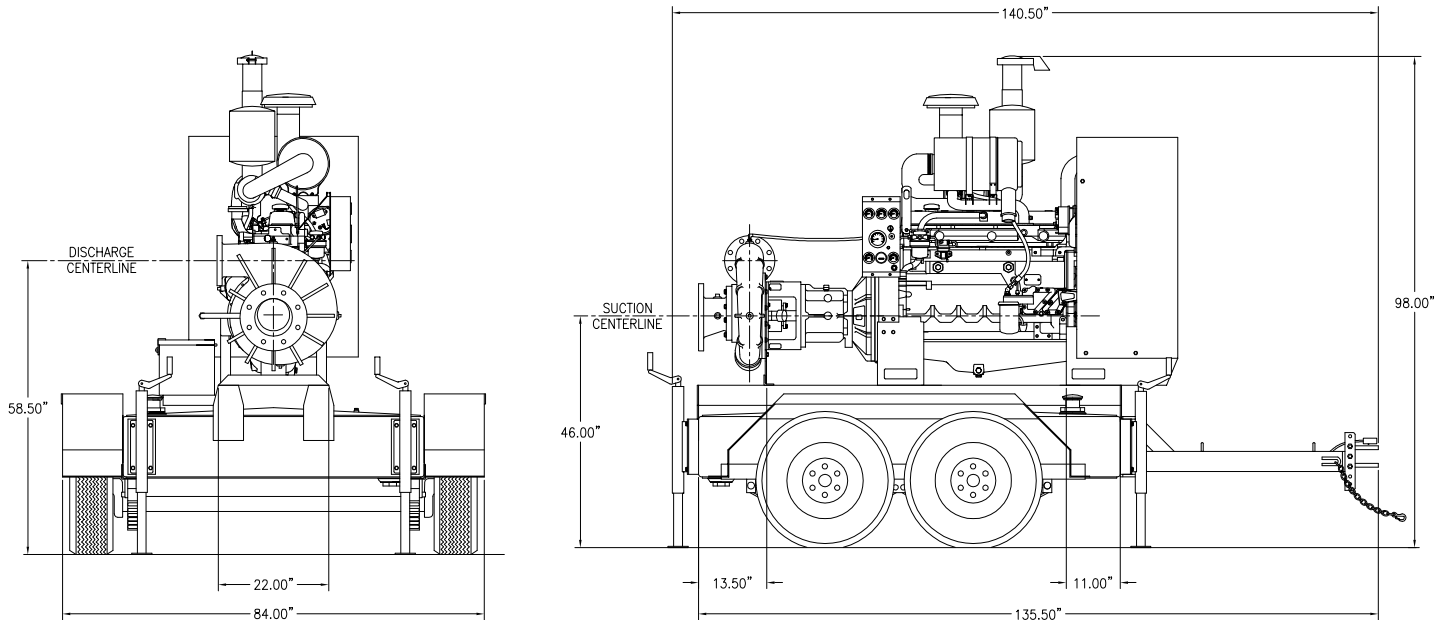
Dimensions:**Standard Model Specifications:****Pump:**

- Pump Size: 8"x5" AISI 150# flanges standard
- Suction Cover: ASTM A48 class 30 gray iron
- Wear Ring: ASTM A48 class 30 gray iron
- Volute Casing: ASTM A48 class 30 gray iron
- Back Plate: ASTM A48 class 30 gray iron
- Mechanical Seal: Tungsten vs silicon carbide seal faces
Viton elastomers, 300 series stainless steel hardware and spring, seal system designed for dry running
- Impeller: Enclosed type, six vane, with 1" spherical solids handling capability stainless steel
- Bearing Housing: ASTM A48 class 30 gray iron

Engine:

- Model: 6068HFC94 iT4
- 200 intermittent horsepower @ 2400
- Six cylinder, six cycle, water cooled diesel engine
- Governor: Electronic
- Lubrication: Force feed

PowerPrime
Pumps

powerprime.com

P.O. Box 2248
Bakersfield, CA 93303

800.647.7246

sales@powerprime.com